



Lodha Developers &lt;developerslodha@gmail.com&gt;

---

**six monthly Compliance monitoring report \_April 2023 to September 2023\_Rajuji Manaji Chawl**

1 message

**Lodha Developers** <developerslodha@gmail.com>

13 January 2024 at 15:44

To: ecompliance-mh@gov.in

Bcc: pristineconsultants@gmail.com

Dear Sir,

This is with reference to Environmental Clearance letter No **SEIAA-EC-0000002321dt.22.01.2019** from SEIAA, Maharashtra.

We are enclosing herewith the detailed six monthly Compliance monitoring report for the period of **April 2023 to September 2023** along with duly filled data sheet for Proposed Redevelopment of **Rajuji Manaji Chawl** on plot bearing CS No. 1/157 of Lower Parel division in G/South Ward situated at Sitaram Jadhav Marg, Mumbai.

Thanks &amp; Regards

Macrotech Developers Ltd.

(Earlier known as LODHA DEVELOPERS LIMITED)

---

 **Six Monthly Compliance Monitoring Report\_Macrotech Developers Ltd\_Rajuji Manaji Chawl\_April 2023 - Sept 2023\_.pdf**

1118K



Lodha Developers &lt;developerslodha@gmail.com&gt;

---

**six monthly Compliance monitoring report \_April 2023 to September 2023\_Rajuji Manaji Chawl**

1 message

**Lodha Developers** <developerslodha@gmail.com>

13 January 2024 at 15:45

To: romumbai@mpcb.gov.in  
Cc: sromumbai1@mpcb.gov.in

Dear Sir,

This is with reference to Environmental Clearance letter No **SEIAA-EC-0000002321dt.22.01.2019** from SEIAA, Maharashtra.We are enclosing herewith the detailed six monthly Compliance monitoring report for the period of **April 2023 to September 2023** along with duly filled data sheet for Proposed Redevelopment of **Rajuji Manaji Chawl** on plot bearing CS No. 1/157 of Lower Parel division in G/South Ward situated at Sitaram Jadhav Marg, Mumbai.Thanks & Regards  
Macrotech Developers Ltd.  
(Earlier known as LODHA DEVELOPERS LIMITED)

---

 **Six Monthly Compliance Monitoring Report\_Macrotech Developers Ltd\_Rajuji Manaji Chawl\_April 2023 - Sept 2023\_.pdf**  
1118K



Lodha Developers &lt;developerslodha@gmail.com&gt;

---

**six monthly Compliance monitoring report \_April 2023 to September 2023\_Rajuji Manaji Chawl**

1 message

---

**Lodha Developers** <developerslodha@gmail.com>  
To: psec.env@maharashtra.gov.in

13 January 2024 at 15:47

Dear Sir,

This is with reference to Environmental Clearance letter No **SEIAA-EC-000002321dt.22.01.2019** from SEIAA, Maharashtra.

We are enclosing herewith the detailed six monthly Compliance monitoring report for the period of **April 2023 to September 2023** along with duly filled data sheet for Proposed Redevelopment of **Rajuji Manaji Chawl** on plot bearing CS No. 1/157 of Lower Parel division in G/South Ward situated at Sitaram Jadhav Marg, Mumbai.

Thanks & Regards  
Macrotech Developers Ltd.  
(Earlier known as LODHA DEVELOPERS LIMITED)

---

 **Six Monthly Compliance Monitoring Report\_Macrotech Developers Ltd\_Rajuji Manaji Chawl\_April 2023 - Sept 2023\_.pdf**  
1120K

Date: 31/11/2023

To,  
**Ministry of Environment, Forest & Climate Change,**  
Regional office (WCZ),  
Ground Floor E wing,  
New Secretariat Building, Civil Line,  
Nagpur 440 001.

**Sub:** Submission of Compliance Report for Proposed Redevelopment of Rajuji Manaji Chawl on plot bearing CS No. 1/157 of Lower Parel division in G/South Ward situated at Sitaram Jadhav Marg, Mumbai.

**Ref:** Environmental Clearance letter No. SEIAA-EC-0000002321 dt. 22.01.2020

Dear Sir,

This is with reference to Environmental Clearance letter No SEIAA-EC-0000002321 dt. 22.01.2020 from SEIAA, Maharashtra.

We are enclosing here with the detailed Compliance report (April, 2023 - September, 2023) along with duly filled data sheet.

Thanking you,  
Yours faithfully,  
**For Macrotech Developers ltd**  
**Formerly Known as LODHA DEVELOPERS LIMITED**



**Authorized Signatory**

**Enclosed:** Copy of Compliance Report for the period of April, 2023 - September, 2023.

**Cc:**

1. Regional Office, MPCB, Sion, Mumbai.
2. Environment Department, Mantralaya, Mumbai

Date: 31/11/2023

To,  
**Principal Secretary, SEIAA,**  
Environment Department,  
Mantralaya,  
Mumbai – 400032

**Sub:** Submission of Compliance Report for Proposed Redevelopment of Rajuji Manaji Chawl on plot bearing CS No. 1/157 of Lower Parel division in G/South Ward situated at Sitaram Jadhav Marg, Mumbai.

**Ref:** Environmental Clearance letter No. SEIAA-EC-0000002321 dt. 22.01.2020

Dear Sir,

This is with reference to Environmental Clearance letter No SEIAA-EC-0000002321 dt. 22.01.2020 from SEIAA, Maharashtra.

We are enclosing here with the detailed Compliance report (April, 2023 - September, 2023) along with duly filled data sheet.

Thanking you,  
Yours faithfully,  
**For Macrotech Developers Ltd**  
**Formerly Known as LODHA DEVELOPERS LIMITED**



**Authorized Signatory**

**Enclosed:** Copy of Compliance Report for the period of April, 2023 - September, 2023.

**Cc:**

1. Regional Office, MPCB, Sion , Mumbai
2. Director, MoEF, Nagpur

Date: 31/11/2023

To,  
**Regional Officer,**  
Kalpataru Point, 1<sup>st</sup> floor,  
Opp.PVR Theatre, Sion (E),  
Mumbai-400022.

**Sub:** Submission of Compliance Report for Proposed Redevelopment of Rajuji Manaji Chawl on plot bearing CS No. 1/157 of Lower Parel division in G/South Ward situated at Sitaram Jadhav Marg, Mumbai.

**Ref:** Environmental Clearance letter No. SEIAA-EC-0000002321 dt.22.01.2020.

Dear Sir,

This is with reference to Environmental Clearance letter No SEIAA-EC-0000002321 dt. 22.01.2020 from SEIAA, Maharashtra.

We are enclosing here with the detailed Compliance report (April, 2023 - September, 2023) along with duly filled data sheet.

Thanking you,  
Yours faithfully,

**For Macrotech Developers Ltd**  
**Formerly Known as LODHA DEVELOPERS LIMITED**



**Authorized Signatory**

**Enclosed:** Copy of Compliance Report for the period of April, 2023 - September, 2023.

**Cc:**

1. Environment Department, Mantralaya, Mumbai
2. Director, MoEF, Nagpur

# COMPLIANCE REPORT

(APRIL 2023 – SEPTEMBER 2023)

For

## PROPOSED REDEVELOPMENT PROJECT OF RAJUJI MANAJI CHAWL

(ENVIRONMENTAL CLEARANCE VIDE LETTER NO. SEAC-EC-0000002321 dt.22.01.2020)

At

Plot bearing CS no. 1/157, of Lower Parel division in  
G/South Ward situated at Sitaram Jadhav Marg,  
Maharashtra.

*Proposed By*

**M/s. Macrotech Developers Ltd**  
(Earlier known as LODHA DEVELOPERS LIMITED)

Project Details

Sr. No.	Particulars	Details
1	Project type :River- valley/mining /Industry/Thermal/Nuclear/other(specify)	Building Construction Project
2	Name of the Project	Redevelopment of Rajuji Manaji Chawl
3	Clearance letter(s)/OM and Date	Environmental Clearance Vide Letter No. SEIAA –EC- 0000002321 dated 22.01.2020.
4	Location	Plot bearing at CS No. 1/157 of lower parcel division in G / South ward situated at Sitaram jadhav Marg, Maharashtra.
	a) District(s)	Thane
	b) State(s)	Maharashtra
	c) Latitude/Longitude	18°59'47.53"N 72°49'40.21"E
5	Address of correspondence	
	a) address of concerned Project Chief Executive (with pin code & telephone/telex/fax numbers)	<b>Mr. Kedar Bakalkar</b> Lodha Excelus, Apollo Mills Compound, N.M Joshi Marg, Locality, Mahalaxmi, Mumbai 400011. Email:kedar.bakalkar@lodhagroup.com
	b) Address of Executive Project Engineer/Manager(with pin code/fax numbers)	Same as above
6	Salient features	
	a) of the Project	1 Sale Wing, 1 Rehab Wing having total 463 Nos. of flats, 38 shops, school (area of 156.92 m <sup>2</sup> ) and 1 Parking Building
	b) of the Environmental Management Plan	Sewage Treatment Plant of total 350 m <sup>3</sup> capacity, Rain Water Harvesting system and Solid waste management through Mechanical Composting details of the same is attached in Annexures
7	Breakup of the project area	
	a) submergence area: forest & non-forest	NA
	b) Others	Total Plot area:3,593.57 m <sup>2</sup>
		FSI area 25,159.85m <sup>2</sup>
		Non FSI area 16,954.31m <sup>2</sup>
		Total Construction Area 42,114.16m <sup>2</sup>
8	Breakup of the project affected population with enumeration of those losing houses/dwelling unit only agricultural land only, both dwelling units & agricultural land & landless laborers/	
	a) SC, ST / Adivasis	N.A.
	b)others (Please indicate whether these figures are based on any scientific and systematic survey carried out or only provisional figures, if a	N.A.



	survey carried out gives details and years of survey)		
9	Financial details:		
	a) Project cost as originally planned and subsequent revised estimates and the year of price reference	Rs.62 Crore	
	b) Allocation made for environmental management plans with item wise and year wise break-up	Construction Cost	150 Lakhs
		Operation & Maintenance Cost	39.3 Lakhs/Year
	c) Benefit cost ratio/Internal rated of Return and the year of assessment	N.A.	
	d) Whether (c) includes the cost of environmental management as shown in the above	N.A.	
	e) Actual expenditure incurred on the environmental management plans so far	N.A.	
10	Forest land requirement	No Forest Land Required.	
	a) The status of approval for diversion of forest land for non-forestry use	N.A.	
	b) The status of clearing felling	N.A.	
	c) The status of compensatory	N.A.	
	d) afforestation, if any	N.A.	
	e) Comments on the viability & sustainability of compensatory afforestation programme in the light of actual field experience so far	N.A.	
11	The status of clear felling in non-forest area (such as submergence area of reservoir, approach roads), if any with quantitative information	N.A.	
12	Status of construction		
	a) Date commencement (Actual and/or planned)		
	b) Date of completion (Actual and/or planned)		
13	Reasons for the delay if the project is yet to start	NA	
14	Dates of site visits		
	a) The dates on which the project was monitored by the Regional office on previous occasions, if any	----	
	b) Date of site visit for this monitoring report	Not yet finalized.	

15	Details of correspondence with project authorities for obtaining action plans/information on status of compliance to safeguards other than the routine letters for logistic support for site visits) (The first monitoring report may contain the details of all the letters issued so far, but the later reports may cover only the letters issued subsequently)	We have received Environmental Clearance Vide Letter No. SEIAA- EC-0000002321 dated 22.01.2020 from Govt. of Maharashtra.
----	--	---

**PRESENT STATUS OF PROPOSED RESIDENTIAL PROJECT AT PLOT BEARING S. NO. 1/157 OF LOWER PAREL DIVISION IN G/SOUTH WARD SITUATED AT SITARAM JADHAV MARG, MUMBAI, MAHARASHTRA.**

**Present Status**

- Sale wing: Terrace and LMR Slab casted.
- Rehab wing : Terrace and LMR Slab casted.
- Parking wing: 10<sup>th</sup> Slab (Terrace) casted.

**Compliance to condition of Environmental Clearance letter no. SEIAA - EC - 0000002321 dated 22.01.2020.**

<b>CONDITIONS</b>		
<b>Specific Conditions:</b>		
I	As agreed by PP, demolition waste and concrete debris can be recycled for making paver blocks and use these in the different project sites of PP.	We agree. We will utilize demolition waste and debris on site for land leveling
II	PP to ensure that 40% area of STP tanks should be open to sky for adequate ventilation	We have provided STP tanks with 40% area open to sky for adequate ventilation
III	PP to ensure that storm water drain should be channel with grating.	Yes, Storm water drain will be proper channel with grating.
IV	PP to abide by all conditions laid down by CFO vide letter dated 31/5/2019 & as by time to time.	Noted and will comply.
V	PP to provide the cul-de-sac for wing B with 12 mt. turning radius for proper fire tender movement.	As per the suggestion of committee, we have provided cul-de-sac for wing B with 12 mt. turning radius for proper fire tender movement.
VI	PP to upload the Architect certificate mentioning Non-FSI area statement.	We have submitted the Architect certificate mentioning the Non FSI area statement.
VII	The PP to get NOC from competent authority with reference to Thane creek flamingo sanctuary if the project site falls within 10 Km radius from the said sanctuary boundary. The planning authority to ensure fulfilment of this condition before granting CC.	Project site is in Mumbai which comes under the Municipal Corporation of Greater Mumbai (MCGM). Our project site is located at approximately 13 km from Thane creek flamingo sanctuary and it does not fall under said sanctuary boundary.
VIII	PP to submit CER prescribed by MoEF & CC circular dated 1.5.2018 relevant to the area and people around the project. The specific activities to be undertaken under CER to be carried out in consultation with Municipal Corporation or collector or Environment Department.	Not applicable
IX	PP to ensure that CER plan gets approved from Municipal Commissioner/District Collector.	Not applicable
X	PP Shall comply with Standard EC conditions mentioned in the Office Memorandum issued by MoEF& CC vide F.No.22-34/2018-IA.III dt.04.01.2019.	We agree

XI	SEIAA decided to grant EC for –FSI: 25159.85 m2, Non-FSI: 16954.31 m2 and Total BUA: 42114.16 m2 (Plan Approval no-P-2342/2019/ (157)G/South/Lower Parel /IOD/New, Date-30.08.2019).	Noted
<b>General Conditions for Pre – construction phase:-</b>		
	<b>Conditions</b>	<b>Compliance</b>
I	E-waste shall be disposed through Authorized vendor as per E-waste (Management and Handling) Rules, 2016.	The household E-waste will be disposed through Authorized vendor as per E- waste (Management and Handling) Rules, 2016.
II	The Occupancy Certificate shall be issued by the Local Planning Authority to the project only after ensuring sustained availability of drinking water, connectivity of sewer line to the project site and proper disposal of treated water as per environmental norms.	Noted
III	This environmental clearance is issued subject to obtaining NOC from Forestry & Wild life angle including clearance from the standing committee of the National Board for Wild life as if applicable & this environment clearance does not necessarily implies that Forestry & Wild life clearance granted to the project which will be considered separately on merit.	NA
IV	PP has to abide by the conditions stipulated by SEAC & SEIAA.	Yes we Agree
V	The height, Construction built up area of proposed construction shall be in accordance with the existing FSI/FAR norms of the urban local body & it should ensure the same along with survey number before approving layout plan & before according commencement certificate to proposed work. Plan approving authority should also ensure the zoning permissibility for the proposed project as per the approved development plan of the area.	Building plans are approved by MCGM as per norms.

VI	If applicable "Consent for Establishment" shall be obtained from Maharashtra Pollution Control Board under Air and Water Act and a copy shall be submitted to the Environment department before start of any construction work at the site.	Consent to establish was obtained from the Maharashtra Pollution Control Board letter no. Format 1.0/BO/JD (WPC)/UAN No. 88900/HOD- CE/CC/2008001257 dated 31.08.2020.
VII	All required sanitary and hygienic measures should be in place before starting construction activities and to be maintained throughout the construction phase.	Yes, We have provided all the required sanitary and hygienic measures on site like toilets and STP, safe drinking water, medical health care etc. during construction phase.
VIII	Adequate drinking water and sanitary facilities should be provided for construction workers at the site. Provision should be made for mobile toilets. The safe disposal of wastewater and solid wastes generated during the construction phase should be ensured.	Drinking water supplied through tanker water supply. Provision of toilets for labour camps has been provided. The solid waste generated from the labour camps is mostly household waste which is collected and disposed off in municipal bins.
IX	The solid waste generated should be properly collected and segregated. Dry/ inert solid waste should be disposed off to the approved sites for land filling after recovering recyclable material.	The Solid waste has been properly collected and disposed off in municipal bins during construction phase.
X	Disposal of muck during construction phase should not create any adverse effect on the neighbouring communities and be disposed taking the necessary precautions for general safety and health aspects of people, only in approval sites with the approval of competent authority.	<p>The muck has been disposed with the permissions of competent authority at approved site.</p> <p>As a precaution, we have barricaded about 10 feet above ground level to create general safety and health aspects of people.</p> <p>Re-utilization strategy for construction debris has been followed. Recycled aggregate is used for filling application.</p>
XI	Arrangement shall be made that waste water and storm water do not get mixed.	We will make such arrangement that storm water and waste water not get mixed. Separate pipeline for SWD & waste water have been provided.
XII	All the topsoil excavated during construction activities should be stored for use in horticulture / landscape development within the project site.	Top layer of soil will be reused for the development of green belt.

XIII	Additional soil for levelling of the proposed site shall be generated within the sites (to the extent possible) so that natural drainage system of the area is protected and improved.	Natural drainage system of area will not be disturbed. The construction is done by taking advantage of natural contour.  No additional soil has been required for levelling as we have done backfilling from the soil generated from site.
XIV	Green Belt Development shall be carried out considering CPCB guidelines including selection of plant species and in consultation with the local DFO/ Agriculture Dept.	The landscape will be developed considering CPCB guidelines. The tree species which will plant is of local variety.
XV	Soil and ground water samples will be tested to ascertain that there is no threat to ground water quality by leaching of heavy metals and other toxic contaminants.	We have tested Soil and water samples through MoEF recognized laboratory. This project being residential project there is no possibility of Contamination of toxic and heavy metals. The copies of the reports are attached.
XVI	Construction spoils, including bituminous material and other hazardous materials must not be allowed to contaminant watercourses and the dumpsites for such material must be secured so that they should not leach into the ground water.	Such types of wastes will not anticipate in this activity. However, all possible measures were taken to avoid contamination of water bodies/streams.
XVII	Any hazardous waste generated during construction phase should be disposed off as per applicable rules and norms with necessary approvals of the Maharashtra Pollution Control Board.	Hazardous waste will not anticipated during construction phase as it is residential project.
XVIII	The diesel generator sets to be used during construction phase should be low sulphur diesel type and should conform to Environments (Protection) Rules prescribed for air and noise emission standards.	The DG sets provided will be of enclosed type and as per CPCB norms.  Two nos. of DG sets in each Sale Tower-500 KVA and Rehab Tower-625 KVA
XIX	The diesel required for operating DG sets shall be stored in underground tanks and if required, clearance from concern authority shall be taken.	The diesel will not be stored on site. The diesel will be procured as and when required.
XX	Vehicles hired for bringing construction material to the site should be in good condition and should have a pollution check certificate and should conform to applicable air and noise emission standards and should be operated only during non-peak hours.	Regular maintenance of construction vehicles is carried out to keep them in good condition. The vehicles having PUC certificate will only be hired. Adequate parking space will be made for construction vehicles inside the construction premises to lessen the impacts on traffic in surrounding areas.

(XXI)	Ambient noise levels should conform to residential standards both during day and night. Incremental pollution loads on the ambient air and noise quality should be closely monitored during construction phase. Adequate measures should be made to reduce ambient air and noise level during construction phase, so as to conform to the stipulated standards by CPCB/MPCB.	The noise levels as well as air quality was monitored from MOEF recognized laboratory. Copy of reports is attached.
(XXII)	Fly ash should be used as building material in the construction as per the provisions of Fly Ash Notification of September 1999 and amended as on 27th August, 2003. (The above condition is applicable only if the project site is located within the 100Km of Thermal Power Stations)	Fly ash containing bricks (AAC Type) will be used for construction
(XXIII)	Ready mixed concrete must be used in building construction.	Noted
XXIV	Storm water control and its re-use as per CGWB and BIS standards for various applications.	We agree
XXV	Water demand during construction should be reduced by use of pre-mixed concrete, curing agents and other best practices referred.	Pre-mixed concrete and curing agents will be used for reducing Water demand during construction phase.
XXVI	The ground water level and its quality should be monitored regularly in consultation with Ground Water Authority.	We will not use the ground water during the construction as well as operational phase
XXVII	The installation of the Sewage Treatment Plant (STP) should be certified by an independent expert and a report in this regard should be submitted to the MPCB and Environment department before the project is commissioned for operation. Discharge of this unused treated effluent, if any should be discharge in the sewer line. Treated effluent emanating from STP shall be recycled/refused to the maximum extent possible. Discharge of this unused treated effluent, if any should be discharge in the sewer line. Treatment of 100% gray water by decentralized treatment should be done. Necessary measures should be made to mitigate the odour problem from STP.	STP will be certified by an independent expert and a report in this regard will be submitted to the Ministry before the project is commissioned for operation.  Sewage will be treated up to tertiary level. The treated sewage will be reused for gardening and flushing purpose.  Progress of the STP- RCC work in progress.



XXVII I	Permission to draw ground water and construction of basement if any shall be obtained from the competent Authority prior to construction/ operation of the project.	We will not use the ground water during the construction as well as operational phase.
XXIX	Separation of gray and black water should be done by the use of dual plumbing line for separation of gray and black water.	Dual plumbing lines will be provided for separation of Grey and black water.
XXX	Fixtures for showers, toilet flushing and drinking should be of low flow either by use of aerators or pressure reducing devices or sensor based control.	Water efficient sanitary features include showers, low flush, dual cistern will be provided.
XXXI	Use of glass may be reduced up to 40% to reduce the electricity consumption and load on air conditioning. If necessary, use high quality double glass with special reflective coating in windows.	The use of glass is less than 40%
XXXII	Roof should meet prescriptive requirement as per Energy Conservation Building Code by using appropriate thermal insulation material to fulfil requirement.	Noted
XXXII I	Energy conservation measures like installation of CFLs/TFLs for lighting the areas outside the building should be integral part of the project design and should be in place before project commissioning. Use CFLs and TFLs should be properly collected and disposed off/sent for recycling as per the prevailing guidelines/ rules of the regulatory authority to avoid mercury contamination. Use of solar panels may be done to the extent possible like installing solar street lights, common solar water heaters systems. Project proponent should install, after checking feasibility, solar plus hybrid non-conventional energy source as source of energy.	Solar street lights and solar hot water system will be provided.

XXXI V	Diesel power generating sets proposed as source of backup power for elevators and common area illumination during operation phase should be of enclosed type and conform to rules made under the Environment (Protection) Act, 1986. The height of stack of DG sets should be equal to the height needed for the combined capacity of all proposed DG sets. Use low sulphur diesel. The location of DG sets may be decided with in consultation with Maharashtra Pollution Control Board.	During operation phase, the provision of DG Sets shall be as per EPA-1986 as well as, guidelines for DG Set installation shall be followed. All DG Sets shall be with acoustic enclosures and will be using low Sulphur diesel. The stack heights shall be as per MPCB prescribed norms.  The enclosed type DG sets for common area like Staircase lift lobby, water and Sewage Pumps, STP, OG tanks etc. will be provided.
XXX V	Noise should be controlled to ensure that it does not exceed the prescribed standards. During night time the noise levels measured at the boundary of the building shall be restricted to the permissible levels to comply with the prevalent regulations.	The noise levels are monitored regularly from MoEF recognized laboratory  Noise Monitoring report is attached
XXX VI	Traffic Congestion near the entry and exit points from the roads adjoining the proposed project site must be avoided. Parking should be fully internalized and no public space should be utilized.	Entry & Exit to the project will be located in such way that it won't affect traffic on the adjoining roads.  Also sufficient parking space will be provided for completed buildings.
XXX VII	Opaque wall should meet prescriptive requirement as per Energy Conservation Building Code, which is proposed to be mandatory for all air-conditioned spaces while it is aspiration for non-air-conditioned spaces by use of appropriate thermal insulation material to fulfil requirement.	Noted
XXX VIII	The building should have adequate distance between them to allow movement of fresh air and passage of natural light, air and ventilation	The Buildings will have adequate distance between them to allow movement of fresh air and passage of natural light, air and ventilation to the premises.
XXXI X	Regular supervision of the above and other measures for monitoring should be in place all through the construction phase, so as to avoid disturbance to the surroundings.	The Regular supervision is carried out by the project in-charge and supervisors are trained in Environmental Management measures.
XL	Under the provisions of Environment (Protection) Act, 1986, legal action shall be initiated against the project proponent if it was found that construction of the project has been started without obtaining environmental clearance.	We have obtained Environmental Clearance Vide Letter No. SEIAA- EC – 0000002321 dated 22.01.2020 from SEIAA, Maharashtra.

XLI	Six monthly monitoring reports should be submitted to the Regional office MoEF, Bhopal with copy to this department and MPCB.	The six-monthly Compliance Reports to Regional Office, MoEF & CC, Env. Dept. Govt. of Maharashtra and MPCB have been submitted.
XLII	Project proponent shall ensure completion of STP, MSW disposal facility, green belt development prior to occupation of the buildings. As agreed during the SEIAA meeting, PP to explore possibility of utilizing excess treated water in the adjacent area for gardening before discharging it into sewer line No physical occupation or allotment will be given unless all above said environmental infrastructure is installed and made functional including water requirement in Para 2. Prior certification from appropriate authority shall be obtained.	We agree
XLIII	Wet garbage should be treated by Organic Waste Converter and treated waste (manure) should be utilized in the existing premises for gardening. And, no wet garbage will be disposed outside the premises. Local authority should ensure this.	Wet garbage will be treated by Organic Waste Converter and treated waste (manure) is utilized in the existing premises for gardening. And, no wet garbage will be disposed outside the existing premises.
XLIV	Local body should ensure that no occupation certificate will be issued prior to operation of STP/MSW site with due permission of MPCB.	Noted. STP, green belt facilities will be developed.
XLV	A complete set of all the documents submitted to Department should be forwarded to the MPCB.	We have submitted all the project details and plans to MPCB while applying to Consent to Establish.
XLVI	In the case of any change (s) in the scope of the project, the project would require a fresh appraisal by this Department.	Noted
XLVII	A separate environment management cell with qualified staff shall be set up for implementation of the stipulated environmental safeguards.	Separate funds will allocated for implementation of environmental protection measures/EMP
XLVII I	Separate funds shall be allocated for implementation of environmental protection measures/EMP along with item-wise breaks-up. These cost shall be included as part of the project cost. The funds earmarked for the environment protection measures shall not be diverted for other purposes and year-wise expenditure should reported to the MPCB & this department.	Separate funds will be allocated for implementation of environmental protection measures/EMP.

XLIX	The project management shall advertise at least in two local newspapers widely circulated in the region around the project, one of which shall be in the Marathi language of the local concerned within seven days of issue of this letter, informing that the project has been accorded environmental clearance and copies of clearance letter are available with the Maharashtra Pollution Control Board and may also be seen at Website at <a href="http://envis.maharashtra.gov.in">http://envis.maharashtra.gov.in</a>	The advertisement was given in two local newspapers
L	Project management should submit half yearly compliance reports in respect of the stipulated prior environment clearance terms and conditions in hard & soft copies to the MPCB & this department, on 1 <sup>st</sup> June & 1 <sup>st</sup> December of each calendar year.	We have submitted the half yearly compliance reports to Environment Department Mantralaya, Regional office, MPCB & MoEF Nagpur.
LI	A copy of the clearance letter shall be sent by proponent to the concerned Municipal Corporation and the local NGO, if any, from whom suggestions/representations, if any, were received while processing the proposal. The clearance letter shall also be put on the website of the Company by the proponent.	Noted.
LII	The proponent shall upload the status of compliance of the stipulated EC conditions, including results of monitored data on their website and shall update the same periodically. It shall simultaneously be sent to the Regional Office of MoEF, the respective Zonal Office of CPCB and the SPCB. The criteria pollutant levels namely; SPM, RSPM, SO <sub>2</sub> , NO <sub>x</sub> (Ambient level as well as stack emissions) or critical sector parameters, indicated for the project shall be monitored and displayed at a convenient location near the main gate of the company in the public domain.	We agree
LIII	The project proponent shall also submit six monthly reports on the status of compliance of the stipulated EC conditions including results of monitored data (both in hard copies as well as by e-mail) to the respective Regional Office of MoEF, the respective Zonal Office of CPCB and the SPCB.	Noted

LIV	The environmental statement for each financial year ending 31st March in Form-V as is mandated to be submitted by the project proponent to the concerned State Pollution Control Board as prescribed under the Environment (Protection) Rules, 1986, as amended subsequently, shall also be put on the website of the company along with the status of compliance of EC conditions and shall also be sent to the respective Regional Officers of MoEF by e-mail.	Noted and will comply.
4.	The environmental clearance is being issued without prejudice to the action initiated under EP Act or any court case pending in the court of law and it does not mean that project proponent has not violated any environmental laws in the past and whatever decision under EP Act or of the Hon'ble court will be binding on the project proponent. Hence this clearance does not give immunity to the project proponent in the case filed against him, if any or action initiated under EP Act.	Noted
5.	In case of submission of false document and noncompliance of stipulated conditions, Authority/ Environment department will revoke or suspend the environmental clearance without any intimation and initiate appropriate legal action under Environmental Protection Act, 1986.	We Agree
6	The Environment department reserves the right to add any stringent condition or to revoke the clearance if conditions stipulated are not implemented to the satisfaction of the department or for that matter, for any other administrative reason.	We Agree
7	<b>Validity of Environment Clearance:</b> The environmental clearance accorded shall be valid for a period of 7 years as per MoEF & CC Notification dated 29 <sup>th</sup> April, 2015.	Noted

8	In case of any deviation or alteration in the project proposed from those submitted to this department for clearance, a fresh reference should be made to the department to assess the adequacy of the condition(s) imposed and to incorporate additional environmental protection measures required, if any	NA
9	The above stipulations would be enforced among others under the Water (Prevention and control of pollution) Act, 1974, the Air (Prevention and Control of Pollution) Act, 1981, the Environment (Protection) Act, 1986 and rules there under, Hazardous Wastes (Management and Handling) Rules, 1989 and its amendments, the public Liability Insurance Act, 1991 and its amendments.	We Agree
10	Any appeal against this environmental clearance shall lie with the National Green Tribunal (Western Zone Bench, Pune), New Administrative Building, 1st Floor, D-, Wing, Opposite Council Hall, Pune, if preferred, within 30 days as prescribed under section 16 of the National Green Tribunal Act, 2010.	Noted



## STATE LEVEL ENVIRONMENT IMPACT ASSESSMENT AUTHORITY

Environment department,  
Room No. 217, 2nd floor,  
Mantralaya, Annexe,  
Mumbai- 400 032.  
Date: January 22, 2020

To,  
**Lodha Developers Limited**  
at Plot bearing CS No. 1/157 of lower parel division in G/South Ward situated at sitaram jadhav marg, Mumbai.

**Subject:** Environment Clearance for Redevelopment of Rajuji Manaji Chawl on plot bearing CS No. 1/157 of lower parel division in G/South Ward situated at sitaram jadhav marg, Mumbai by Lodha Developers Limited

Sir,

This has reference to your communication on the above mentioned subject. The proposal was considered as per the EIA Notification - 2006, by the State Level Expert Appraisal Committee-II, Maharashtra in its 1222nd meeting and recommend the project for prior environmental clearance to SEIAA. Information submitted by you has been considered by State Level Environment Impact Assessment Authority in its 184th meetings.

2. It is noted that the proposal is considered by SEAC-II under screening category 8(a) as per EIA Notification 2006.

### Brief Information of the project submitted by you is as below :-

1.Name of Project	Redevelopment of Rajuji Manaji Chawl
2.Type of institution	Private
3.Name of Project Proponent	Lodha Developers Limited
4.Name of Consultant	Mahabal Enviro Engg. Pvt. Ltd.; Dr. D. A. Patil
5.Type of project	Redevelopment of Project
6.New project/expansion in existing project/modernization/diversification in existing project	New Project
7.If expansion/diversification, whether environmental clearance has been obtained for existing project	Not applicable
8.Location of the project	Plot bearing CS No. 1/157 of lower parel division in G/South Ward situated at sitaram jadhav marg, Mumbai.
9.Taluka	Mumbai
10.Village	Lower Parel
Correspondence Name:	Atul Jangam; Lodha Developers Limited
Room Number:	-
Floor:	-
Building Name:	Lodha Excelus
Road/Street Name:	N. M. Joshi Marg
Locality:	Mahalaxmi
City:	Mumbai
11.Whether in Corporation / Municipal / other area	Municipal Corporation of Greater Mumbai
12.IOD/IOA/Concession/Plan Approval Number	Applied for IOD <b>IOD/IOA/Concession/Plan Approval Number:</b> P-2342 / 2019 / (157) / G / South / Lower parel / 337 / 1 / New dated 24.05.2019 <b>Approved Built-up Area:</b>

**SEIAA Meeting No: 184 Meeting Date: December 30, 2019 (**  
**SEIAA-STATEMENT-0000003510 )**  
**SEIAA-MINUTES-0000002900**  
**SEIAA-EC-0000002321**

Page 1 of 14

  
**Shri. Anil Diggikar (Member Secretary**  
**SEIAA)**

13.Note on the initiated work (If applicable)	No work started on site
14.LOI / NOC / IOD from MHADA/ Other approvals (If applicable)	-
15.Total Plot Area (sq. m.)	3593.57 m2
16.Deductions	111.24 m2
17.Net Plot area	3482.33 m2
18 (a).Proposed Built-up Area (FSI & Non-FSI)	FSI area (sq. m.): 25,159.85
	Non FSI area (sq. m.): 16,954.31
	Total BUA area (sq. m.): 42114.16
18 (b).Approved Built up area as per DCR	Approved FSI area (sq. m.): -
	Approved Non FSI area (sq. m.): -
	Date of Approval: 01-01-1900
19.Total ground coverage (m2)	1795.22
20.Ground-coverage Percentage (%) (Note: Percentage of plot not open to sky)	52%
21.Estimated cost of the project	620000000

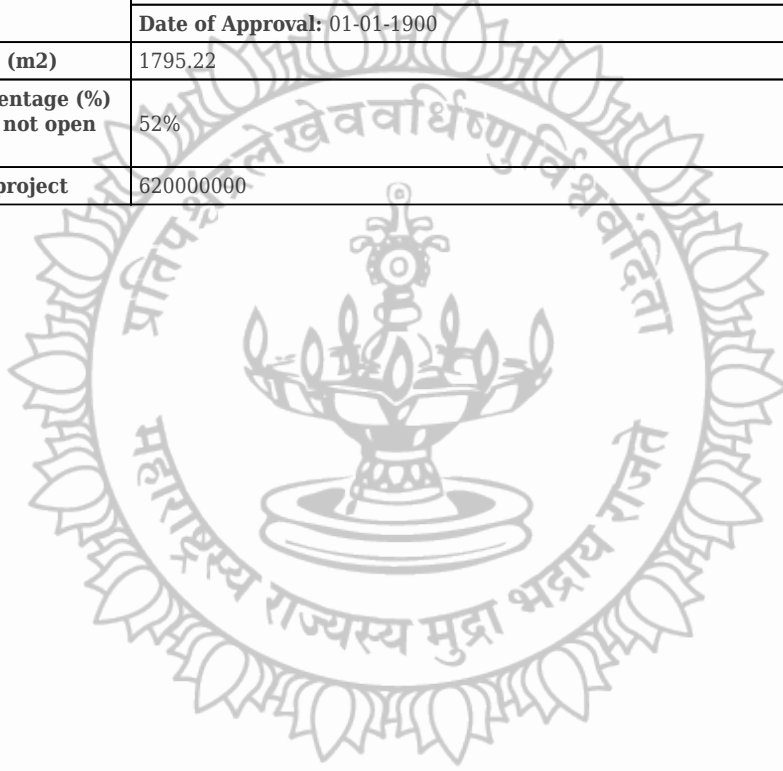

# Government of Maharashtra



## 22. Production Details

Serial Number	Product	Existing (MT/M)	Proposed (MT/M)	Total (MT/M)
1	Not applicable	Not applicable	Not applicable	Not applicable

## 23. Total Water Requirement

<b>Dry season:</b>	Source of water	MCGM
	Fresh water (CMD):	213
	Recycled water - Flushing (CMD):	108
	Recycled water - Gardening (CMD):	3
	Swimming pool make up (Cum):	2
	<b>Total Water Requirement (CMD) :</b>	322
	Fire fighting - Underground water tank(CMD):	As per NBC
	Fire fighting - Overhead water tank(CMD):	As per NBC
	Excess treated water	185
<b>Wet season:</b>	Source of water	MCGM + RWH
	Fresh water (CMD):	183
	Recycled water - Flushing (CMD):	108
	Recycled water - Gardening (CMD):	-
	Swimming pool make up (Cum):	2
	<b>Total Water Requirement (CMD) :</b>	322
	Fire fighting - Underground water tank(CMD):	As per NBC
	Fire fighting - Overhead water tank(CMD):	As per NBC
	Excess treated water	188
<b>Details of Swimming pool (If any)</b>	Swimming pool is provided	

## 24.Details of Total water consumed

Particulars	Consumption (CMD)			Loss (CMD)			Effluent (CMD)		
	Existing	Proposed	Total	Existing	Proposed	Total	Existing	Proposed	Total
Domestic	Not applicable	Not applicable	Not applicable	Not applicable	Not applicable	Not applicable	Not applicable	Not applicable	Not applicable

<b>25.Rain Water Harvesting (RWH)</b>	Level of the Ground water table:	3-4 m
	Size and no of RWH tank(s) and Quantity:	2 RWH Tanks, Total Capacity: 65 KL
	Location of the RWH tank(s):	Underground
	Quantity of recharge pits:	-
	Size of recharge pits :	-
	Budgetary allocation (Capital cost) :	Rs. 15 Lakh
	Budgetary allocation (O & M cost) :	Rs. 0.7 Lakh/yr
	Details of UGT tanks if any :	UG Tanks are Provided

<b>26.Storm water drainage</b>	Natural water drainage pattern:	Towards North Side
	Quantity of storm water:	260.36 m <sup>3</sup> /hr
	Size of SWD:	400 x 600 mm wide internal SWD drain.

<b>27.Sewage and Waste water</b>	Sewage generation in KLD:	299
	STP technology:	MBBR Technology
	Capacity of STP (CMD):	Total Capacity: 350 KLD
	Location & area of the STP:	Ground and 4th to 8th Podium Floor of Wing C
	Budgetary allocation (Capital cost):	Rs. 85 Lakh
	Budgetary allocation (O & M cost):	Rs. 20 Lakh/year

## 28.Solid waste Management

<b>Waste generation in the Pre Construction and Construction phase:</b>	<b>Waste generation:</b>	1194 m3
	<b>Disposal of the construction waste debris:</b>	The construction debris waste will be disposed as per construction debris and demolition waste management Rules 2016
<b>Waste generation in the operation Phase:</b>	<b>Dry waste:</b>	477 kg/d
	<b>Wet waste:</b>	715 kg/d
	<b>Hazardous waste:</b>	NA
	<b>Biomedical waste (If applicable):</b>	NA
	<b>STP Sludge (Dry sludge):</b>	3 KLD
	<b>Others if any:</b>	-
<b>Mode of Disposal of waste:</b>	<b>Dry waste:</b>	Dry garbage will be disposed off to recyclers
	<b>Wet waste:</b>	Wet garbage will be composted using Mechanical Composting Technology and used as organic manure for landscaping.
	<b>Hazardous waste:</b>	NA
	<b>Biomedical waste (If applicable):</b>	NA
	<b>STP Sludge (Dry sludge):</b>	Sludge use as manure for landscaping
	<b>Others if any:</b>	NA
<b>Area requirement:</b>	<b>Location(s):</b>	on ground
	<b>Area for the storage of waste &amp; other material:</b>	60 m2
	<b>Area for machinery:</b>	28 m2
<b>Budgetary allocation (Capital cost and O&amp;M cost):</b>	<b>Capital cost:</b>	Rs. 32 Lakh
	<b>O &amp; M cost:</b>	Rs. 13 Lakh / yr

# Government of Maharashtra

## 29.Effluent Charecterestics

Serial Number	Parameters	Unit	Inlet Effluent Charecterestics	Outlet Effluent Charecterestics	Effluent discharge standards (MPCB)
1	Not applicable	Not applicable	Not applicable	Not applicable	Not applicable
Amount of effluent generation (CMD):		Not applicable			
Capacity of the ETP:		Not applicable			
Amount of treated effluent recycled :		Not applicable			
Amount of water send to the CETP:		Not applicable			
Membership of CETP (if require):		Not applicable			
Note on ETP technology to be used		Not applicable			
Disposal of the ETP sludge		Not applicable			



# Government of Maharashtra

### 30. Hazardous Waste Details

Serial Number	Description	Cat	UOM	Existing	Proposed	Total	Method of Disposal
1	Not applicable	Not applicable	Not applicable	Not applicable	Not applicable	Not applicable	Not applicable

### 31. Stacks emission Details

Serial Number	Section & units	Fuel Used with Quantity	Stack No.	Height from ground level (m)	Internal diameter (m)	Temp. of Exhaust Gases
1	Not applicable	Not applicable	Not applicable	Not applicable	Not applicable	Not applicable

### 32. Details of Fuel to be used

Serial Number	Type of Fuel	Existing	Proposed	Total
1	Not applicable	Not applicable	Not applicable	Not applicable

33. Source of Fuel: Not applicable

34. Mode of Transportation of fuel to site: Not applicable

### 35. Energy

<b>Power requirement:</b>	Source of power supply :	BEST
	During Construction Phase: (Demand Load)	200 kVA
	DG set as Power back-up during construction phase	200 kVA
	During Operation phase (Connected load):	6.2 MW
	During Operation phase (Demand load):	2.1 MW
	Transformer:	2 x 1600 kVA
	DG set as Power back-up during operation phase:	1 x 500 kVA; 1 x 600 kVA
	Fuel used:	HSD
	Details of high tension line passing through the plot if any:	No

### Energy saving by non-conventional method:

LED lighting in common area, lifts lobbies, staircase. Façade light and infra lighting.  
Solar water heating for top 5 floors

### 36. Detail calculations & % of saving:

Serial Number	Energy Conservation Measures	Saving %
---------------	------------------------------	----------

1	Total energy Saving	>20%		
<b>37.Details of pollution control Systems</b>				
<b>Source</b>	<b>Existing pollution control system</b>	<b>Proposed to be installed</b>		
Not applicable	Not applicable	Not applicable		
<b>Budgetary allocation (Capital cost and O&amp;M cost):</b>	<b>Capital cost:</b>	Rs. 12 Lakh		
	<b>O &amp; M cost:</b>	Rs. 0.6 Lakh/yr		
<b>38.Environmental Management plan Budgetary Allocation</b>				
<b>a) Construction phase (with Break-up):</b>				
<b>Serial Number</b>	<b>Attributes</b>	<b>Parameter</b>	<b>Total Cost per annum (Rs. In Lacs)</b>	
1	Water spray for dust suppression	-	8	
2	Site sanitation and potable water supply to labour	-	5	
3	Site sanitation and potable water supply to labour	-	5	
4	Solid Waste Management	-	2	
5	Disinfection	-	4	
6	Safety Personal Protective Equipment	-	8	
7	Traffic Management	-	5	
8	Safety Nets	-	15	
9	Safety Training to Workers	-	2	
<b>b) Operation Phase (with Break-up):</b>				
<b>Serial Number</b>	<b>Component</b>	<b>Description</b>	<b>Capital cost Rs. In Lacs</b>	<b>Operational and Maintenance cost (Rs. in Lacs/yr)</b>
1	STP (Tertiary)	Continuos O & M	85	20
2	Solar System	Weekly	12	0.6
3	Rain Water Harvesting	During Rainy Season	15	0.7
4	Solid waste composting	Continuous O & M	32	13
5	Landscape	Daily	6	1
6	Environmental Monitoring	As per CPCB guidelines through MoEF approved laboratories	-	4
<b>39.Storage of chemicals (inflammable/explosive/hazardous/toxic substances)</b>				

Description	Status	Location	Storage Capacity in MT	Maximum Quantity of Storage at any point of time in MT	Consumption / Month in MT	Source of Supply	Means of transportation
Not applicable	Not applicable	Not applicable	Not applicable	Not applicable	Not applicable	Not applicable	Not applicable
<b>40.Any Other Information</b>							
No Information Available							



# Government of Maharashtra

	<b>CRZ/ RRZ clearance obtain, if any:</b>	Not Applicable
	<b>Distance from Protected Areas / Critically Polluted areas / Eco-sensitive areas/ inter-State boundaries</b>	Not Applicable
	<b>Category as per schedule of EIA Notification sheet</b>	8(a)
	<b>Court cases pending if any</b>	No
	<b>Other Relevant Informations</b>	-
	<b>Have you previously submitted Application online on MOEF Website.</b>	No
	<b>Date of online submission</b>	-

**3. The proposal has been considered by SEIAA in its 184th meeting & decided to accord environmental clearance to the said project under the provisions of Environment Impact Assessment Notification, 2006 subject to implementation of the following terms and conditions:**

**Specific Conditions:**

<b>I</b>	As agreed by PP, demolition waste, and concrete debris can be recycled for making paver blocks and use these in the different project sites of PP.
<b>II</b>	PP to ensure that 40% area of STP tanks should be open to sky for adequate ventilation
<b>III</b>	PP to ensure that storm water drain should be channel with grating.
<b>IV</b>	PP to abide by all conditions laid down by CFO vide letter dated 31/5/2019 & as by time to time.
<b>V</b>	PP to provide the cul-de-sac for wing B with 12 mt turning radius for proper fire tender movement.
<b>VI</b>	PP to upload the Architect certificate mentioning Non-FSI area statement.
<b>VII</b>	The PP to get NOC from competent authority with reference to Thane creek flamingo sanctuary if the project site falls within 10 Km radius from the said sanctuary boundary. The planning authority to ensure fulfilment of this condition before granting CC.
<b>VIII</b>	PP to submit CER prescribed by MoEF&CC circular dated 1.5.2018 relevant to the area and people around the project. The specific activities to be undertaken under CER to be carried out in consultation with Municipal Corporation or collector or Environment Department.
<b>IX</b>	PP to ensure that CER plan gets approved from Municipal Commissioner/District Collector.
<b>X</b>	PP Shall comply with Standard EC conditions mentioned in the Office Memorandum issued by MoEF& CC vide F.No.22-34/2018-IA.III dt.04.01.2019.
<b>XI</b>	SEIAA decided to grant EC for -FSI:25159.85 m2, Non-FSI:16954.31 m2 and Total BUA: 42114.16 m2 ( Plan Approval no-P-2342/2019/(157)G/South/Lower Parel/IOD/New, Date-30.08.2019)

**General Conditions:**

<b>I</b>	E-waste shall be disposed through Authorized vendor as per E-waste (Management and Handling) Rules, 2016.
<b>II</b>	The Occupancy Certificate shall be issued by the Local Planning Authority to the project only after ensuring sustained availability of drinking water, connectivity of sewer line to the project site and proper disposal of treated water as per environmental norms.
<b>III</b>	This environmental clearance is issued subject to obtaining NOC from Forestry & Wild life angle including clearance from the standing committee of the National Board for Wild life as if applicable & this environment clearance does not necessarily implies that Forestry & Wild life clearance granted to the project which will be considered separately on merit.
<b>IV</b>	PP has to abide by the conditions stipulated by SEAC& SEIAA.



V	The height, Construction built up area of proposed construction shall be in accordance with the existing FSI/FAR norms of the urban local body & it should ensure the same along with survey number before approving layout plan & before according commencement certificate to proposed work. Plan approving authority should also ensure the zoning permissibility for the proposed project as per the approved development plan of the area.
VI	If applicable Consent for Establishment" shall be obtained from Maharashtra Pollution Control Board under Air and Water Act and a copy shall be submitted to the Environment department before start of any construction work at the site.
VII	All required sanitary and hygienic measures should be in place before starting construction activities and to be maintained throughout the construction phase.
VIII	Adequate drinking water and sanitary facilities should be provided for construction workers at the site. Provision should be made for mobile toilets. The safe disposal of wastewater and solid wastes generated during the construction phase should be ensured.
IX	The solid waste generated should be properly collected and segregated. dry/inert solid waste should be disposed off to the approved sites for land filling after recovering recyclable material.
X	Disposal of muck during construction phase should not create any adverse effect on the neighboring communities and be disposed taking the necessary precautions for general safety and health aspects of people, only in approved sites with the approval of competent authority.
XI	Arrangement shall be made that waste water and storm water do not get mixed.
XII	All the topsoil excavated during construction activities should be stored for use in horticulture / landscape development within the project site.
XIII	Additional soil for leveling of the proposed site shall be generated within the sites (to the extent possible) so that natural drainage system of the area is protected and improved.
XIV	Green Belt Development shall be carried out considering CPCB guidelines including selection of plant species and in consultation with the local DFO/ Agriculture Dept.
XV	Soil and ground water samples will be tested to ascertain that there is no threat to ground water quality by leaching of heavy metals and other toxic contaminants.
XVI	Construction spoils, including bituminous material and other hazardous materials must not be allowed to contaminate watercourses and the dumpsites for such material must be secured so that they should not leach into the ground water.
XVII	Any hazardous waste generated during construction phase should be disposed off as per applicable rules and norms with necessary approvals of the Maharashtra Pollution Control Board.
XVIII	The diesel generator sets to be used during construction phase should be low sulphur diesel type and should conform to Environments (Protection) Rules prescribed for air and noise emission standards.
XIX	The diesel required for operating DG sets shall be stored in underground tanks and if required, clearance from concern authority shall be taken.
XX	Vehicles hired for bringing construction material to the site should be in good condition and should have a pollution check certificate and should conform to applicable air and noise emission standards and should be operated only during non-peak hours.
XXI	Ambient noise levels should conform to residential standards both during day and night. Incremental pollution loads on the ambient air and noise quality should be closely monitored during construction phase. Adequate measures should be made to reduce ambient air and noise level during construction phase, so as to conform to the stipulated standards by CPCB/MPCB.
XXII	Fly ash should be used as building material in the construction as per the provisions of Fly Ash Notification of September 1999 and amended as on 27th August, 2003. (The above condition is applicable only if the project site is located within the 100Km of Thermal Power Stations).
XXIII	Ready mixed concrete must be used in building construction.
XXIV	Storm water control and its re-use as per CGWB and BIS standards for various applications.
XXV	Water demand during construction should be reduced by use of pre-mixed concrete, curing agents and other best practices referred.
XXVI	The ground water level and its quality should be monitored regularly in consultation with Ground Water Authority.
XXVII	The installation of the Sewage Treatment Plant (STP) should be certified by an independent expert and a report in this regard should be submitted to the MPCB and Environment department before the project is commissioned for operation. Discharge of this unused treated effluent, if any should be discharge in the sewer line. Treated effluent emanating from STP shall be recycled/refused to the maximum extent possible. Discharge of this unused treated effluent, if any should be discharge in the sewer line. Treatment of 100% gray water by decentralized treatment should be done. Necessary measures should be made to mitigate the odour problem from STP.
XXVIII	Permission to draw ground water and construction of basement if any shall be obtained from the competent Authority prior to construction/operation of the project.

XXIX	Separation of gray and black water should be done by the use of dual plumbing line for separation of gray and black water.
XXX	Fixtures for showers, toilet flushing and drinking should be of low flow either by use of aerators or pressure reducing devices or sensor based control.
XXXI	Use of glass may be reduced up to 40% to reduce the electricity consumption and load on air conditioning. If necessary, use high quality double glass with special reflective coating in windows.
XXXII	Roof should meet prescriptive requirement as per Energy Conservation Building Code by using appropriate thermal insulation material to fulfill requirement.
XXXIII	Energy conservation measures like installation of CFLs /TFLs for the lighting the areas outside the building should be integral part of the project design and should be in place before project commissioning. Use CFLs and TFLs should be properly collected and disposed off/sent for recycling as per the prevailing guidelines/rules of the regulatory authority to avoid mercury contamination. Use of solar panels may be done to the extent possible like installing solar street lights, common solar water heaters system. Project proponent should install, after checking feasibility, solar plus hybrid non-conventional energy source as source of energy.
XXXIV	Diesel power generating sets proposed as source of backup power for elevators and common area illumination during operation phase should be of enclosed type and conform to rules made under the Environment (Protection) Act, 1986. The height of stack of DG sets should be equal to the height needed for the combined capacity of all proposed DG sets. Use low sulphur diesel. The location of the DG sets may be decided with in consultation with Maharashtra Pollution Control Board.
XXXV	Noise should be controlled to ensure that it does not exceed the prescribed standards. During nighttime the noise levels measured at the boundary of the building shall be restricted to the permissible levels to comply with the prevalent regulations.
XXXVI	Traffic congestion near the entry and exit points from the roads adjoining the proposed project site must be avoided. Parking should be fully internalized and no public space should be utilized.
XXXVII	Opaque wall should meet prescriptive requirement as per Energy Conservation Building Code, which is proposed to be mandatory for all air-conditioned spaces while it is aspiration for non-air-conditioned spaces by use of appropriate thermal insulation material to fulfill requirement.
XXXVIII	The building should have adequate distance between them to allow movement of fresh air and passage of natural light, air and ventilation.
XXXIX	Regular supervision of the above and other measures for monitoring should be in place all through the construction phase, so as to avoid disturbance to the surroundings.
XL	Under the provisions of Environment (Protection) Act, 1986, legal action shall be initiated against the project proponent if it was found that construction of the project has been started without obtaining environmental clearance.
XLI	Six monthly monitoring reports should be submitted to the Regional office MoEF, Bhopal with copy to this department and MPCB.
XLII	Project proponent shall ensure completion of STP, MSW disposal facility, green belt development prior to occupation of the buildings. As agreed during the SEIAA meeting, PP to explore possibility of utilizing excess treated water in the adjacent area for gardening before discharging it into sewer line No physical occupation or allotment will be given unless all above said environmental infrastructure is installed and made functional including water requirement in Para 2. Prior certification from appropriate authority shall be obtained.
XLIII	Wet garbage should be treated by Organic Waste Converter and treated waste (manure) should be utilized in the existing premises for gardening. And, no wet garbage will be disposed outside the premises. Local authority should ensure this.
XLIV	Local body should ensure that no occupation certification is issued prior to operation of STP/MSW site etc. with due permission of MPCB.
XLV	A complete set of all the documents submitted to Department should be forwarded to the Local authority and MPCB.
XLVI	In the case of any change(s) in the scope of the project, the project would require a fresh appraisal by this Department.
XLVII	A separate environment management cell with qualified staff shall be set up for implementation of the stipulated environmental safeguards.
XLVIII	Separate funds shall be allocated for implementation of environmental protection measures/EMP along with item-wise breaks-up. These cost shall be included as part of the project cost. The funds earmarked for the environment protection measures shall not be diverted for other purposes and year-wise expenditure should reported to the MPCB & this department.
XLIX	The project management shall advertise at least in two local newspapers widely circulated in the region around the project, one of which shall be in the Marathi language of the local concerned within seven days of issue of this letter, informing that the project has been accorded environmental clearance and copies of clearance letter are available with the Maharashtra Pollution Control Board and may also be seen at Website at <a href="http://ec.maharashtra.gov.in">http://ec.maharashtra.gov.in</a> .

<b>L</b>	Project management should submit half yearly compliance reports in respect of the stipulated prior environment clearance terms and conditions in hard & soft copies to the MPCB & this department, on 1st June & 1st December of each calendar year.
<b>LI</b>	A copy of the clearance letter shall be sent by proponent to the concerned Municipal Corporation and the local NGO, if any, from whom suggestions/representations, if any, were received while processing the proposal. The clearance letter shall also be put on the website of the Company by the proponent.
<b>LII</b>	The proponent shall upload the status of compliance of the stipulated EC conditions, including results of monitored data on their website and shall update the same periodically. It shall simultaneously be sent to the Regional Office of MoEF, the respective Zonal Office of CPCB and the SPCB. The criteria pollutant levels namely; SPM, RSPM, SO <sub>2</sub> , NO <sub>x</sub> (ambient levels as well as stack emissions) or critical sector parameters, indicated for the project shall be monitored and displayed at a convenient location near the main gate of the company in the public domain.
<b>LIII</b>	The project proponent shall also submit six monthly reports on the status of compliance of the stipulated EC conditions including results of monitored data (both in hard copies as well as by e-mail) to the respective Regional Office of MoEF, the respective Zonal Office of CPCB and the SPCB.
<b>LIV</b>	The environmental statement for each financial year ending 31st March in Form-V as is mandated to be submitted by the project proponent to the concerned State Pollution Control Board as prescribed under the Environment (Protection) Rules, 1986, as amended subsequently, shall also be put on the website of the company along with the status of compliance of EC conditions and shall also be sent to the respective Regional Offices of MoEF by e-mail.



# Government of Maharashtra

4. The environmental clearance is being issued without prejudice to the action initiated under EP Act or any court case pending in the court of law and it does not mean that project proponent has not violated any environmental laws in the past and whatever decision under EP Act or of the Hon'ble court will be binding on the project proponent. Hence this clearance does not give immunity to the project proponent in the case filed against him, if any or action initiated under EP Act.

5. In case of submission of false document and non-compliance of stipulated conditions, Authority/ Environment Department will revoke or suspend the Environment clearance without any intimation and initiate appropriate legal action under Environmental Protection Act, 1986.

6. The Environment department reserves the right to add any stringent condition or to revoke the clearance if conditions stipulated are not implemented to the satisfaction of the department or for that matter, for any other administrative reason.

7. Validity of Environment Clearance: The environmental clearance accorded shall be valid as per EIA Notification, 2006, and amendments by MoEF&CC Notification dated 29th April, 2015.

8. In case of any deviation or alteration in the project proposed from those submitted to this department for clearance, a fresh reference should be made to the department to assess the adequacy of the condition(s) imposed and to incorporate additional environmental protection measures required, if any.

9. The above stipulations would be enforced among others under the Water (Prevention and Control of Pollution) Act, 1974, the Air (Prevention and Control of Pollution) Act, 1981, the Environment (Protection) Act, 1986 and rules there under, Hazardous Wastes (Management and Handling) Rules, 1989 and its amendments, the public Liability Insurance Act, 1991 and its amendments.

10. Any appeal against this Environment clearance shall lie with the National Green Tribunal (Western Zone Bench, Pune), New Administrative Building, 1st Floor, D- Wing, Opposite Council Hall, Pune, if preferred, within 30 days as prescribed under Section 16 of the National Green Tribunal Act, 2010.

  
Shri. Anil Diggikar (Member Secretary SEIAA)

**Copy to:**

1. SHRI JOHNY JOSEPH, CHAIRMAN-SEIAA
2. SHRI UMAKANT DANGAT, CHAIRMAN-SEAC-I
3. SHRI M.M.ADTANI, CHAIRMAN-SEAC-II
4. SHRI ANIL .D. KALE. CHAIRMAN SEAC-III
5. SECRETARY MOEF & CC
6. IA- DIVISION MOEF & CC
7. MEMBER SECRETARY MAHARASHTRA POLLUTION CONTROL BOARD MUMBAI
8. REGIONAL OFFICE MOEF & CC NAGPUR
9. MUNICIPAL COMMISSIONER MUMBAI
10. MUNICIPAL COMMISSIONER NAVI MUMBAI
11. REGIONAL OFFICE MPCB MUMBAI
12. REGIONAL OFFICE MPCB NAVI MUMBAI
13. REGIONAL OFFICE MIDC ANDHERI
14. REGIONAL OFFICE MIDC KOPER KHAIRANE NAVI MUMBAI
15. MAHARASHTRA STATE ELECTRICITY DISTRIBUTION CO. LTD
16. COLLECTOR OFFICE MUMBAI
17. COLLECTOR OFFICE MUMBAI SUB-URBAN

## MAHARASHTRA POLLUTION CONTROL BOARD

Phone : 24010437/24020781  
/24037124/24035273  
Fax : 24044532/24024068  
/24023516  
Email : [jdwater@mpcb.gov.in](mailto:jdwater@mpcb.gov.in)  
Visit At : <http://mpcb.gov.in>



Kalpataru Point, 3rd & 4th floor,  
Sion- Matunga Scheme Road No. 8,  
Opp. Cine Planet Cinema,  
Near Sion Circle, Sion (E),  
Mumbai - 400022

Infrastructure /Red/LSI

Date-31/08/2020

Consent No: Format1.0/BO/JD(WPC)/UAN No. 88900/HOD- CE/CC/ 2008001257

To,  
M/s RAJUJI MANAJI PROJECT,  
1/157, LOWER PAREL DIVISION,  
Mumbai

Subject: Consent to Establish in Red Category for construction project.

Ref : 1. Your application vide UAN No.0000088900 Dated: 13.02.2020.

For: Consent to Establish for construction project.

under Section 25 of the Water (Prevention & Control of Pollution) Act, 1974 & under Section 21 of the Air (Prevention & Control of Pollution) Act, 1981 and Authorization under Rule 5 of the Hazardous and Other Wastes (M & TM) Rules, 2016 is considered and the consent is hereby granted subject to the following terms and conditions and as detailed in the schedule I, II, III& IV annexed to this order:

1. The consent is granted for a period up to: Commissioning of the project or of 5 years whichever is earlier.
2. The proposed capital investment of the project is Rs. 62.0 Crs. (As per CA Certificate submitted by project proponent).

Consent to Establish is valid for construction project named as M/s RAJUJI MANAJI PROJECT, 1/157, LOWER PAREL DIVISION, Mumbai having total plot area of 3593.57 Sqm and total construction BUA of 42114.16 sq. mtr as per EC dtd 22.01.2020 including utilities and services as per construction commencement Certificate issued by local body.

### 3. Conditions under Water (P&CP), 1974 Act for discharge of effluent:

Sr. No.	Description	Permitted quantity of discharge (CMD)	Standards to be achieved	Disposal
1	Trade effluent	NIL	NA	NA
2	Domestic effluent	299	As per Schedule -I	60% should be reused & recycled and remaining should be discharged in municipal sewer

### 4. Conditions under Air (P&CP) Act, 1981 for air emissions:

Sr. No.	Description of stack/ source	Capacity	Number Of Stack	Standards to be achieved
-	NA	-	-	-

### 5. Conditions under Solid Waste Management Rules, 2016:

Sr. no.	Type Of Waste	Quantity & UoM	Treatment	Disposal
1	Wet garbage	715 Kg/Day	OWC	Used as Manure
2	Dry garbage	477 Kg/Day	-	Segregate and Hand over to Local Body for recycling
3	STP Sludge	14 Kg/Day	-	Used as Manure

6. Conditions under Hazardous and Other Wastes (M & TM) Rules, 2016 for treatment and disposal of hazardous waste: NA

Sr. No.	Type of Waste	Category	Quantity	UOM	Disposal
—	—NA—	—	—	—	—

7. The Board reserves the right to review, amend, suspend, revoke etc. this consent and the same should be binding on the industry.
8. This consent should not be construed as exemption from obtaining necessary NOC/permission from any other Government authorities.
9. Project Proponent shall comply the Construction and Demolition Waste Management Rules, 2016 which is notified by Ministry of Environment, Forest and Climate Change dtd.29/03/2016.
10. Project Proponent shall install online monitoring systems for pH, TSS and flow at the outlet of STP.
11. Project Proponent shall provide Organic waste digester with composting facility or Biogas digester with composting facility.
12. Project Proponent shall submit an affidavit in Board's prescribed format within 15 days regarding the compliance of conditions of EC/CRZ clearance and C to E.
13. The Project Proponent shall comply with the condition of Environmental clearance obtained vide No SEIAA-EC-00002321 dtd 22.01.2020.

For and on behalf of the  
Maharashtra Pollution Control Board

(Dr. Y. B. Sontakke)  
Joint Director,  
Water Pollution Control

Received Consent fee of -

Sr. No.	Amount (Rs.)	Transaction No.	Date
1	100000	NEFT 5459209	20.02.2020

Copy to:

1. Regional Officer, MPCB, Mumbai and Sub-Regional Officer, MPCB, Mumbai-I  
- They are directed to ensure the compliance of the consent conditions.
2. Chief Accounts Officer, MPCB, Mumbai.
3. CC/CAC desk- for record & website updating purposes.

Schedule-I

Terms & conditions for compliance of Water Pollution Control:

- 1) A) As per your application, you have proposed to install Sewage Treatment Plant (STP) with design capacity of 350 CMD based on MBBR Technology.
- B) The Applicant shall operate the effluent treatment plant (STP) to treat the sewage so as to achieve the following standards prescribed by the Board or under EP Act, 1986 and Rules made there under from time to time, whichever is stringent.

Sr No.	Parameters	Standards prescribed by Board
		Limiting Concentration
1	pH	6.5 to 9.0
2	BOD (3 days 27oC)	10mg/l
3	Suspended Solids	20mg/l
4	COD	50mg/l
5	Total Nitrogen	10 mg/l
6	Ammonical Nitrogen	5 mg/l
7	Fecal Coliform	100 MPN/100ml

- C) The treated effluent shall be 60% recycled for secondary purposes such as toilet flushing, air conditioning, firefighting, etc and remaining shall be used on land for gardening
- D) Project proponent shall operate STP for five years from the date of obtaining occupation certificate.

The Board reserves its rights to review plans, Specifications or other data relating to plant setup for the treatment of waterworks for the purification thereof & the system for the disposal of sewage or trade effluent or in connection with the grant of any consent conditions. The Applicant should obtain prior consent of the Board to take steps to establish the unit or establish any treatment and disposal system or and extension or addition thereto

- 2) The industry should ensure replacement of pollution control system or its parts after expiry of its expected life as defined by manufacturer so as to ensure the compliance of standards and safety of the operation thereof.
- 3) The Applicant shall comply with the provisions of the Water (Prevention & Control of Pollution) Act, 1974 and as amended, by installing water meters and other provisions as contained in the said act.

Sr. no.	Purpose for water consumed	Water consumption quantity (CMD)
1	Domestic purpose	322

- 4) The Applicant shall provide Specific Water Pollution control system as per the conditions of EP Act, 1986 and rule made there under from time to time.

*[Handwritten signature]*

Schedule-II

Terms & conditions for compliance of Air Pollution Control:

1. As per your application, you have proposed to install the Air pollution control (APC) system and also proposed to erect following stack (s) and to observe the following fuel pattern-

Sr. No.	Stack Attached To	APC System	Height in Mtrs.*	Type Of Fuel	Quantity	UOM	S%	SO <sub>2</sub> Kg/day
-	—NA—	-	-	-	-	-	-	-

\* Above roof of the building in which it is installed.

2. The applicant should operate and maintain above mentioned air pollution control system, so as to achieve the level of pollutants to the following standards.

Particulate matter	Not to exceed	150 mg/Nm <sup>3</sup> .
--------------------	---------------	--------------------------

3. The Applicant should obtain necessary prior permission for providing additional control equipment with necessary specifications and operation thereof or alteration or replacement alteration well before its life come to an end or erection of new pollution control equipment.

The Board reserves its rights to vary all or any of the condition in the consent, if due to any technological improvement or otherwise such variation (including the change of any control equipment, other in whole or in part is necessary).



**Schedule-III**  
**Details of Bank Guarantees**

Sr. No.	Consent (C to E/O/R)	Amt of BG Imposed	Submission Period	Purpose of BG	Compliance Period	Validity Date
1	Consent to Establish	Rs. 10 Lakhs	15 Days	Towards Compliance of Environmental Clearance & Consent conditions.	Upto Commissioning of the project	COU or Five years

The above Bank Guarantees shall be submitted in favour of Regional Officer, Mumbai and shall be submitted to Regional Office, Mumbai.

Maharashtra Pollution Control Board

Schedule-IV

General Conditions:

The following general conditions shall apply as per the type of the industry.

- 1) The applicant shall provide facility for collection of samples of sewage effluents, air emissions and hazardous waste to the Board staff at the terminal or designated points and shall pay to the Board for the services rendered in this behalf.
- 2) The firm shall strictly comply with the Water (P&CP) Act, 1974, Air (P&CP) Act, 1981 and environmental protection Act 1986 and Solid Waste Management Rules, 2016 and E-Waste (Management) Rules, 2016.
- 3) Drainage system shall be provided for collection of sewage effluents. Terminal manholes shall be provided at the end of the collection system with arrangement for measuring the flow. No sewage shall be admitted in the pipes/sewers downstream of the terminal manholes. No sewage shall find its way other than in designed and provided collection system.
- 4) Vehicles hired for bringing construction material to the site should be in good condition and should conform to applicable air and noise emission standards and should be operated only during non-peak hours.
- 5) Conditions for D.G. Set
  - a) Noise from the D.G. Set should be controlled by providing an acoustic enclosure or by treating the room acoustically.
  - b) Industry should provide acoustic enclosure for control of noise. The acoustic enclosure/ acoustic treatment of the room should be designed for minimum 25 dB (A) insertion loss or for meeting the ambient noise standards, whichever is on higher side. A suitable exhaust muffler with insertion loss of 25 dB (A) shall also be provided. The measurement of insertion loss will be done at different points at 0.5 meters from acoustic enclosure/room and then average.
  - c) The industry shall take adequate measures for control of noise levels from its own sources within the premises in respect of noise to less than 55 dB(A) during day time and 45 dB(A) during the night time. Day time is reckoned between 6 a.m. to 10 p.m and night time is reckoned between 10 p.m to 6 a.m.
  - d) Industry should make efforts to bring down noise level due to DG set, outside industrial premises, within ambient noise requirements by proper siting and control measures.
  - e) Installation of DG Set must be strictly in compliance with recommendations of DG Set manufacturer.
  - f) A proper routine and preventive maintenance procedure for DG set should be set and followed in consultation with the DG manufacturer which would help to prevent noise levels of DG set from deteriorating with use.
  - g) D.G. Set shall be operated only in case of power failure.
  - h) The applicant should not cause any nuisance in the surrounding area due to operation of D.G. Set.
  - i) The applicant shall comply with the notification of MoEF dated 17.05.2002 regarding noise limit for generator sets run with diesel.
- 6) Solid Waste – The applicant shall provide onsite municipal solid waste processing system & shall comply with Solid Waste Management Rules, 2016 & E-Waste (M) Rules, 2016.
- 7) Affidavit undertaking in respect of no change in the status of consent conditions and compliance of the consent conditions the draft can be downloaded from the official web site of the MPCB.
- 8) The treated sewage shall be disinfected using suitable disinfection method.
- 9) The firm shall submit to this office, the 30th day of September every year, the environment statement report for the financial year ending 31st march in the prescribed Form-V as per the provision of rule 14 of the Environmental (Protection) Second Amended rule 1992.
- 10) The applicant shall obtain Consent to Operate from Maharashtra Pollution Control Board before commissioning of the project.

**Annexure - I**

**PROJECT DETAILS**

Name of project : Environment Clearance for Redevelopment of Rajuji Manaji Chawl on plot bearing CS No. 1/157 of lower parcel division in G/South Ward Situated at Sitaram jadhav marg, Mumbai Maharashtra.

Name of Developer Lodha Developers Pvt. Ltd.

**Area Statement:**

<b>Sr. No.</b>	<b>Details</b>	<b>Area (m2)</b>
1.	Total Plot Area	3593.57
2.	F.S.I. Area	25,159.85
3.	Non F.S.I. Area	16,954.31
4.	Total Construction Area	42,114.16

## **Annexure - II**

### **SOLID WASTE MANAGEMENT PLAN**

- Wet Garbage: 715 kg/day.
- Dry Garbage: 477 kg/day.
- The biodegradable and non-biodegradable waste will be segregated at source of waste generation. Then this will be separately disposed in municipal waste disposal system.
- Biodegradable garbage will be composted using mechanical composting
- Dry garbage will be segregated & disposed off to recyclers

**ANNEXURE III**

**SEWAGE TREATMENT PLANT**

Technology Used: Moving Bed Biofilm Reactor (MBBR)

STP – 350 KLD

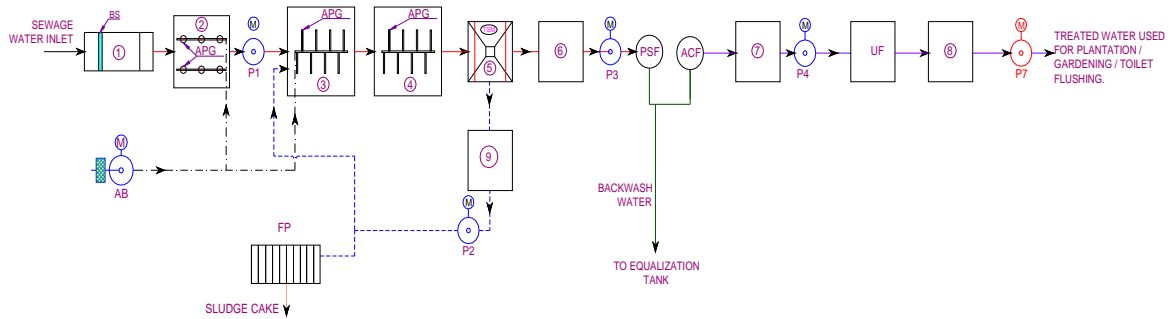

	PROCESS UNIT
<b>Sr. No.</b>	<b>PARTS NAME</b>
<b>1.</b>	<b>Screen Chamber cum Oil &amp; Grease Chamber</b>
<b>2.</b>	<b>Equalization tank</b>
<b>3.</b>	<b>MBBR 1 tank</b>
<b>4.</b>	<b>MBBR 2 tank</b>
<b>5.</b>	<b>Tube settler</b>
<b>6.</b>	<b>Supernatant Tank</b>
<b>7.</b>	<b>UF Feed Tank</b>
<b>8.</b>	<b>Treated Water Tank</b>
<b>9.</b>	<b>Sludge Sump</b>

**ANNEXURE IV  
WATER BUDGET**

Particulars	No of Flats/ Area	Occupancy	Total Population	Water Requirement Basis (in lpcd)*		Total Water Requirement/ person	Water Demand KLD
				Domestic	Flushing		
<b>Residential Bldg</b>	463	5	2315	90	45	135	313
Shop (Area)	38	3	114	25	20	45	5
School	137.8	1 person/2.5 m2	55	25	20	45	2
Swimming Pool							2
<b>Total</b>			<b>2,484</b>				<b>322</b>
<b>Sewage Generation</b>				<b>90 % of Domestic &amp; 100 % of Flushing Requirement</b>			<b>299</b>
<b>Sludge</b>				<b>1 % of Sewage Generation</b>			<b>3</b>
<b>Recycling for Flushing</b>							
<b>Residential Bldg</b>	463	5	2315		45	45	104
Shop (Area)	38	3	114		20	20	2
School	137.8	1 person per 10 m2	55		20	20	1
<b>Total</b>			<b>2,484</b>				<b>108</b>
Recycling for Gardening	627.22					5l/m <sup>2</sup>	3
Total Recycling Water							50
<b>Excess Treated Water to Municipal Sewer</b>							<b>135</b>

**ANNEXURE V**

**ENVIRONMENTAL MANAGEMENT PLAN  
DURING CONSTRUCTION PHASE**

Sr. No.	Environmental Components	Predicted Impacts	Probable source of Impact	Mitigation Measures	Remarks
<b>CONSTRUCTION PHASE</b>					
1.	Ambient Air Quality	Negative impact inside construction site premises. No negative impact outside site.	Dust emissions from excavation, air emissions from machinery and other construction activities at site.	Dust reduction measures such as road watering. Periodic maintenance of construction equipment. Use of good quality fuels. Use of Personal Protective Equipment's	Impacts are temporary during construction phase. Impacts will be confined to short distances, as coarse particles will settle within the short distance from activities.
2.	Noise	Negative impact near noise generation sources inside premises. No significant impact on ambient noise levels in the surrounding area.	Noise generated from construction activities and operation of construction equipment and DG sets	Use of well-maintained equipment. Heavy construction activity limited to day-time hours only. Use of noise mufflers in and construction vehicle. Use of earplugs/muffs by construction staff.	Temporary impacts during construction phase. No blasting or other high noise activities envisaged.
3.	Water	No significant negative impact.	Surface runoff from project site. Oil/fuel and waste spills. Improper debris disposal. Discharge of sewage from labour camp.	Silt fences to reduce runoff Secondary containment and dykes in material storage areas. Sewage treatment in septic tanks.	Labour will be employed to reduce size of labour camps. No perennial surface water resource adjacent to site. No excavation work will be done.
4.	Land	Minor negative impact	Excavation, Construction debris, waste from labour camp.	Reutilization and recycling of construction debris Waste from labour camps will be collected and composted on site. Non compostable waste will be transported to landfill site. Topsoil will be conserved and used for landscaping in functional phase.	-

5.	Aesthetic s	Minor negative impacts	Construction activities and Excavation	The impacts will be compensated by extensive tree plantation and gardening in the use phase.	Short term impact restricted only in the initial stages of construction.
----	----------------	------------------------------	--	--	--



## ANNEXURE VI

## EMP COST

Component	Capital Cost (Rs. In Lakhs)	O & M Cost (Rs. In Lakhs/year)	Frequency
STP (Tertiary)	81	19	Continuous O & M Environment Monitoring: Monthly, STP outlet water quality for pH, BOD, COD, SS, FC, Nitrate, Phosphate and O&G
Solar Hot water and Solar Street Light	12	0.6	Quarterly
Rainwater harvesting	15	0.7	During rainy season (cleaning of SWD, Contour trenches and filtration units before rainy season)
Solid Waste Composting plant	32	13	Continuous O & M Environment Monitoring: Monthly to assess the compost quality
Landscape	6	1	Daily
Environmental Monitoring		4	As per the CPCB guidelines through MoEF Approved laboratories
<b>Total Cost</b>	<b>146</b>	<b>37</b>	

### Site Photographs



Labor Camp



Labor Camp Toilets



Drinking Water tank for Labor camp

Annexure VIII  
News Paper Advertisement

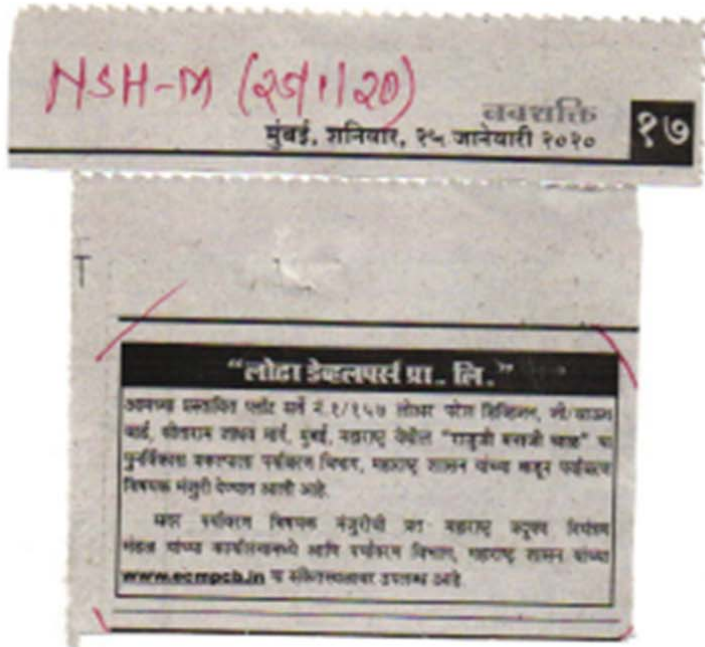



## ANALYSIS REPORT FOR AMBIENT AIR QUALITY

Name of the Client:  LODHA DEVELOPERS PRIVATE LIMITED AT LOWER PAREL, MUMBAI-MAHARASHTRA	Report Date	: 24.08.2023			
	Report No	: NIL/OT/08/23/143			
	Reference	: Verbal Discussion			
	Date of Sampling	: 18.08.2023			
	Date of Analysis	: 19.08.2023			
	Duration of Monitoring	: 8 Hours			
	Sampling Location	: Project Site			
	Sampling done by	: Pristine Consultants			
Sampling Procedure	: N(I)/AIR/SOP-12/13/14				
<b>RESULT</b>					
Sr. No	Parameters	Result	NAAQS Limits	Unit	Method
1	Particulate Matter (PM10)	81.2	100	µg/m <sup>3</sup>	IS 5182(part 23): reaffirmed : 2017
2	Particulate Matter (PM2.5)	36.8	60	µg/m <sup>3</sup>	Lab SOP No.NIL/AIR SOP/03,based on CPCB Guideline Volume-1: 2011
3	Sulphur Dioxide (SO2)	26.3	80	µg/m <sup>3</sup>	IS 5182 Part 2, reaffirmed: 2017
4	Nitrogen Dioxide (NOX)	38.5	80	µg/m <sup>3</sup>	IS 5182 Part 6, reaffirmed: 2017

For NETEL (INDIA) LIMITED

Lab Incharge



## ANALYSIS REPORT FOR AMBIENT NOISE

<b>Name of the Client:</b>		<b>Report Date</b> : 24.08.2023			
LODHA DEVELOPERS PRIVATE LIMITED AT LOWER PAREL, MUMBAI-MAHARASHTRA.		<b>Report No</b> : NIL/OT/08/23/144			
		<b>Reference</b> : Verbal Discussion			
		<b>Date of Monitoring</b> : 18.08.2023			
		<b>Sample Details</b> : Noise Monitoring level			
		<b>Sampling done by</b> : Pristine Consultants			
		<b>Sampling Procedure</b> : As per the Reference method			
<b>RESULT</b>					
Sr. No	Location	Result dB(A) Day	Result dB(A) Day	Ambient Noise Standards in dB(A)	Method
1	Project Site	55.4	45.8	55*/45*	IS 9876:1981 & Manufacturer Manual, WI/S/5/35&36, Issue no. 3, Issue date 10.04.2014

**Remark:**

Limit During Day time < 55. (Day time shall mean from 6.00 am to 10.00 pm.)

Limit

During Night time < 45. (Night time shall mean from 10.00 pm to 6.00 am.)

As per Code of practice for Controlling Noise prescribed by Noise Pollution Committee from Sources other than Industries and Automobiles, the maximum noise levels near the construction site should be limited to 75 dB(A) Leq (5 min.) in industrial areas and to 65 dB(A) Leq(5 min.) in other areas.<http://envfor.nic.in/citizen/specinfo/noise.html>

For NETEL (INDIA) LIMITED

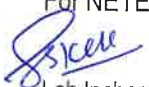
  
Lab Incharge

MoEF Recognized Laboratory





## ANALYSIS REPORT FOR WATER

Name of the Client:	Report Date : 24.08.2023
LODHA DEVELOPERS PRIVATE LIMITED AT LOWER PAREL, MUMBAI-MAHARASHTRA	Report No : NIL/OT/08/23/145
	Reference : Verbal Discusssion
	Date of Sampling : 18.08.2023
	Date of Analysis : 19.08.2023
	Test Location : Project Site
	Sampling done by : Pristine Consultants
	Sampling Procedure : IS 3025 (P-1)

## RESULT

Sr. No	Parameter	Result	Unit	IS desirable Limit (As per IS 10500:2012)	Method
--------	-----------	--------	------	--	--------

## PHYSICO-CHEMICAL PARAMETERS

1	Colour	Colourless	Hazon	--	IS 3025(part4)
2	Odour	Agreeable	--	--	IS 3025(part5)
3	Taste	Agreeable	--	--	IS 3025(part 8)
4	pH	7.36	--	6.5-8.5	IS 3025 Part11:1983: RA 2017
5	Turbidity	<1	NTU	1	IS 3025 Part 10:1984RA: 2017
6	Alkalinity	128	mg/lit	200	IS 3025 part 23: 1986RA-2019
7	Total Hardness	168	mg/lit	200	IS 3025 (Part 21): 2009 EDTA method, RA: 2019
8	Total Dissolved Solids	174	mg/lit	500	IS : 3025 (Part 16):1984, RA 2017
9	Chloride	18.2	mg/lit	250	IS 3025 (part 32):1988, RA: 2019
10	Calcium	2.9	mg/lit	75	IS 3025( part 40):1991, EDTA method, RA:2019
11	Magnesium	2.7	mg/lit	30	IS 3025(part 46):1999, RA: 2019
12	Sulphate	BDL	mg/lit	200	IS 3025 (Part 24): 1988,RA: 2019
13	Copper	BDL	mg/lit	0.05	APHA 3111 B, 23rdEdition Additional Air-Acetylene flame AAS method:2017
14	Nitrate	BDL	mg/lit	45	IS : 3025 ( Part 34) :1988, RA 2019

## BACTERIOLOGICAL TEST

15	Total Coliform	Absent	MPN/100ml	ABSENT	IS 1622
----	----------------	--------	-----------	--------	---------

BDL : Below Detectable Limit

Remark : Test results related only to the sample tested.

: The Complaint register is available with the laboratory as per Environment protection act 1986.

For NETEL (INDIA) LIMITED

  
 Lab Incharge



## ANALYSIS REPORT FOR SOIL

<b>Name of the Client:</b>  LODHA DEVELOPERS PRIVATE LIMITED AT LOWER PAREL, MUMBAI-MAHARASHTRA.	<b>Report Date</b> : 24.08.2023 <b>Report No</b> : NIL/OT/08/23/146 <b>Reference</b> : Verbal Discussion <b>Date of Sampling</b> : 18.08.2023 <b>Date of Analysis</b> : 19.08.2023 <b>Test Location</b> : Project Site <b>Sampling done by</b> : Pristine Consultants <b>Sampling Procedure</b> : NIL/SOIL/SOP-11
---	--

### RESULT

Sr. No	Parameter	Result	Unit	Method
1	pH (1:5 Suspension)	7.36	--	IS 2720 Part 26 :1987
2	Moisture	2.8	%	Lab SOP No. NIL/SOP/06 Based on Manual of Soil testing in india, Ministry of Agriculture, GOI: 2011
3	Electrical Conductivity (at 250oC)	4.2	Mmhos/cm	IS 14767:2000
4	Organic Carbon	6.2	%	Lab SOP No. NIL/SOP/05 Based on Manual of Soil testing in India, Ministry of Agriculture, GOI: 2011
5	Cation Exchange Capacity	2.4	Meq/100g m	Lab SOP No. NIL/SOP/08 Based on Manual of Soil testing in India, Ministry of Agriculture, GOI : 2011
6	Available Nitrogen	58.8	mg/kg	APHA 4500-Norg-B,23rd Ed 2017
7	Available Phosphorus	62.3	mg/kg	APHA 4500-P,23rd Ed 2017
8	Available Potassium	74.2	mg/kg	Lab SOP No. NIL/SOP/10 Based on Manual of Soil testing in India, Ministry of Agriculture, GOI : 2011
9	Sodium	2.8	mg/kg	Lab SOP No. NIL/SOP/10 Based on Manual of Soil testing in India, Ministry of Agriculture, GOI : 2011
10	Copper	<2	mg/kg	EPA 3050 B Air- Acetylene flame AAS Method : 1996
11	Zinc	<2.5	mg/kg	EPA 3050 B Air- Acetylene flame AAS Method : 1996
12	Total Chromium	<5	mg/kg	EPA 3050 B Air- Acetylene flame AAS Method : 1996
13	Cadmium	<5	mg/kg	EPA 3050 B Air- Acetylene flame AAS Method : 1996
14	Lead	<1	mg/kg	EPA 3050 B Air- Acetylene flame AAS Method : 1996

BDL : Below Detectable Limit

Remark : Test results related only to the sample tested.

For NETEL (INDIA) LIMITED

Lab Incharge

A Neterwala Group Company

CIN : U74999MH2003PLC142228

Office & Laboratory : W-408, Rabale MIDC, TTC Industrial Area, Navi Mumbai - 400 701.

Phone : 72080976 92 / 93 / 94 / 95 • Website : www.netel-india.com • E-mail : ems@netel-india.com

Registered office : Liberty Building, 3rd Floor, Sir Vithaldas Thackersey Marg, (New Marine Lines), Mumbai - 400 020.

